

# facnor

FURLING SYSTEMS



**IMPORTANT** : before assembling make sure that the diameter of turnbuckle cage does not exceed the dimensions below.

Model	FD110	FD190	FD230	FD310
Max turnbuckle cage Ø (mm)	24	38	38	46

If the diameter of the open cage is too important, try a closed cage.

## INSTALLATION MANUAL

### FD110-190-230-310 MODELS

Congratulations, you have purchased a Facnor reefing system. Over 20 years Facnor has gained an excellent reputation in manufacturing furling systems that feature Innovation and Reliability. Sturdy and easy-to-use, your Facnor reefing system will give you satisfaction when either cruising or racing.

## TABLE OF CONTENTS

1- Assembly drawing .....	p. 18
2- Package inventory .....	p. 18
2.1 – Box content .....	p. 19
2.2 – Tube content .....	p. 20
2.3 – Determining which section length should be used .....	p. 20
3- Pre-installation notes .....	p. 21/22
4- Assembly stages .....	p. 23
4.1 – Assembly of the halyard deflector .....	p. 23
4.2 – Assembly of the top cap and the top section .....	P. 23
4.3 – Fitting the halyard swivel .....	p. 24
4.4 – Assembling foil sections .....	p. 24
4.5 – Fitting the telescopic section .....	p. 24
4.6 – Fitting the feeder .....	p. 25
4.7 – Fitting the bushing into the telescopic section .....	p. 25
4.8 – Fixing the telescopic section in the drum .....	p. 25
4.9 – Fixing the bottom of the drum .....	p. 26
4.10 – Adjusting sections .....	p. 27
4.11 – Fixing the sail feeder .....	p. 27
5- Installation of the reefing line/webbing .....	p. 28
5.1 – Fitting the reefing line/webbing .....	p. 28
5.2 – Fitting the 1st lead block .....	P. 28
5.3 – Cutting the webbing .....	p. 28/29
5.4 – Fitting the webbing into the drum .....	p. 29
6- Adjusting the furling line guide .....	p. 29
7- Specific installations .....	p. 30
8- Furling tips .....	p. 31

**Before beginning assembly, we recommend that you read these instructions carefully so as to familiarize yourself with the parts, installation and the use of your Facnor furling and reefing system.**

## 1- ASSEMBLY DRAWING

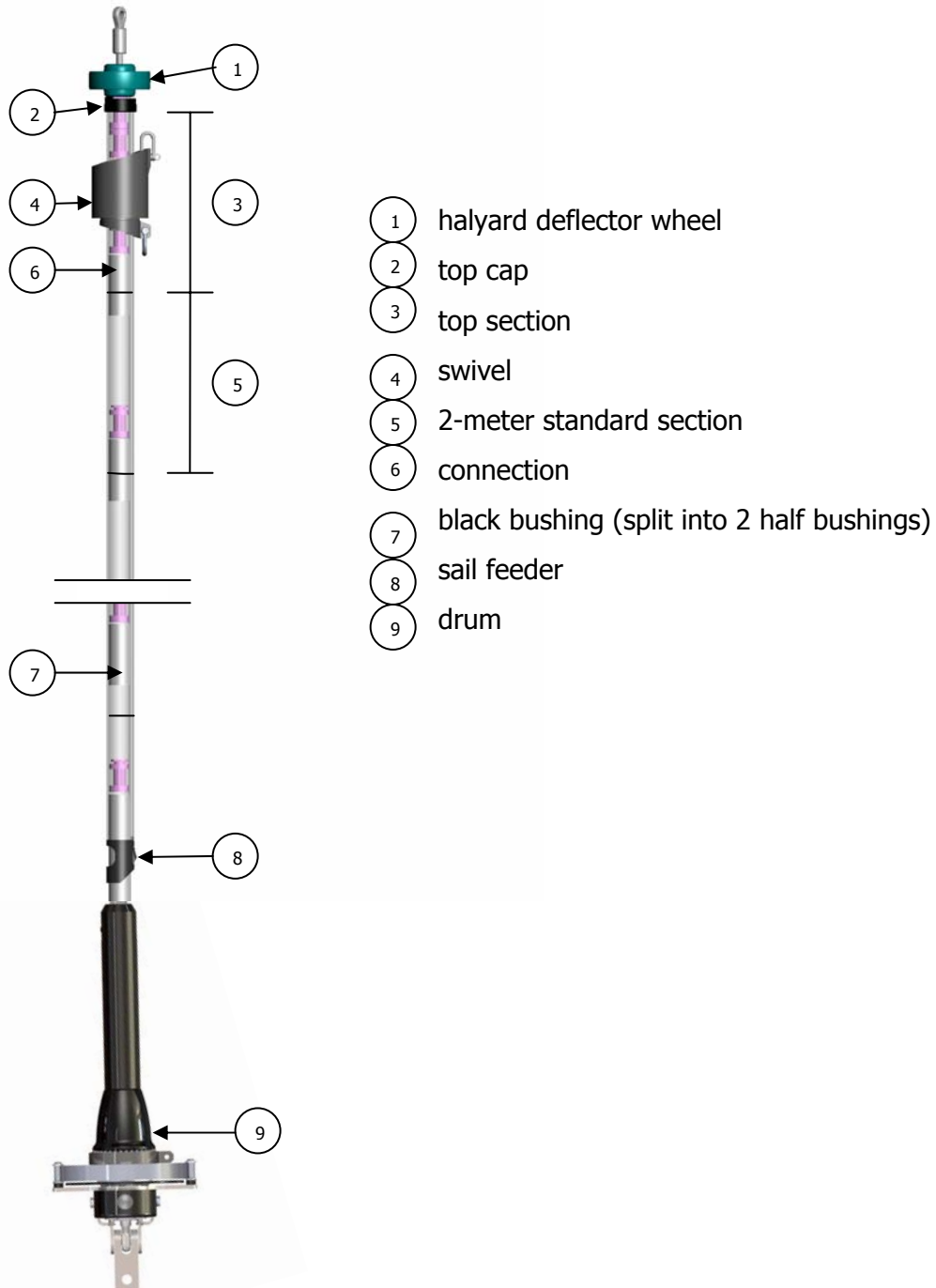

## 2- PACKAGE INVENTORY

The Facnor headsail reefing system comprises:



### 2.1 BOX CONTENT

#### 2.1.1 Standard components

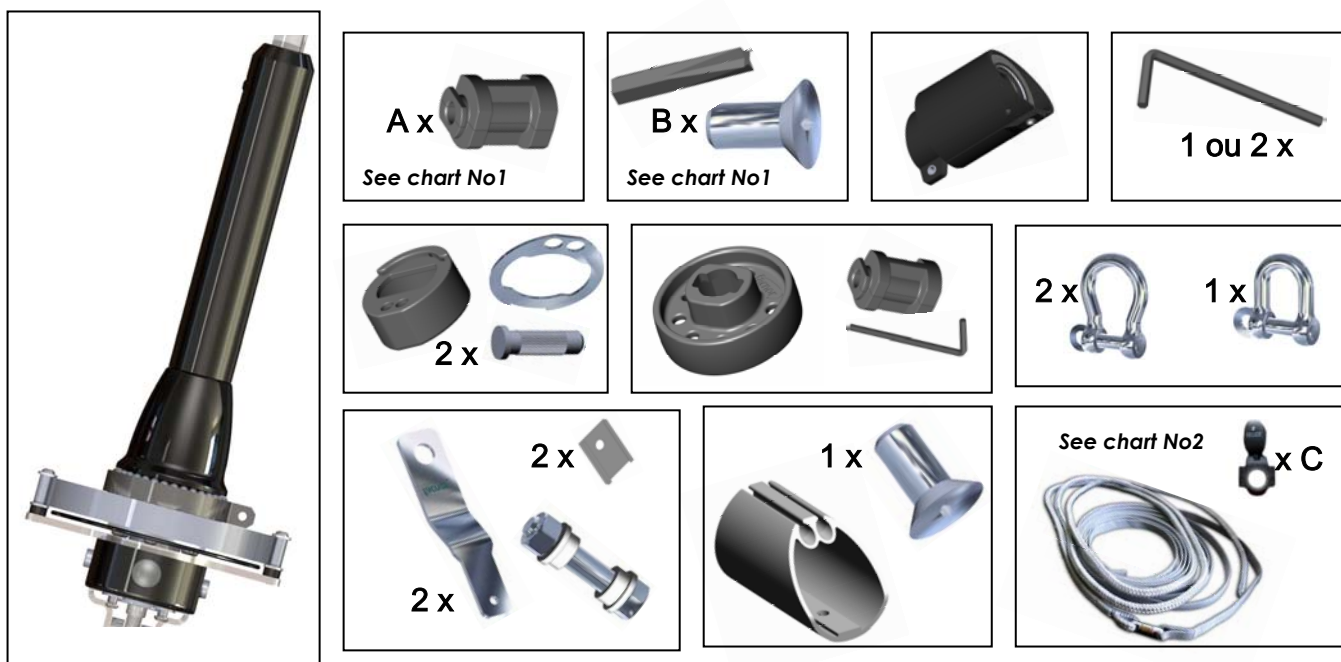

Chart No1

Maximum forestay length	8M30	10M40	12M40	14M40	16M40	18M40	20M40	22M40
A = Number of bushings necessary*	7	8	9	10	11	12	13	14
B = Number of screws necessary *	16	20	24	28	32	36	40	44

\* **NOTE** : the quantity contained in the bag is superior to the number of screws or bushings required

Chart No2

Models	FD110	FD190	FD230	FD310
Rope length x Ø	9M x Ø 08MM	13M x Ø 10MM	15M x Ø 10MM	18M x Ø 10MM
Webbing length	8M	16M	16M	27M
Quantity C	4	4	4	5

## 2.2 TUBE CONTENT

1. one telescopic section (1M40)
2. external twin-groove sections
3. connectors

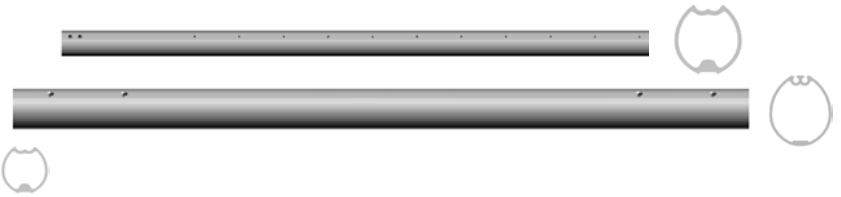

\* For OEM furling systems, delivered originally to the shipyard, the top section may be shorter than 2 meters. For those systems, the top section is cut at a specific length.

Example : if you order an FD190 **12M40**, according to the chart below you will receive **five 2-meter sections, one half-length section, the telescopic section and five connectors**.

Chart No.3

Forestay max. length	No. of 2m sections	No. of 1m sections	No. of connectors	Telescopic section
7M30	3	0	2	1
8M40	3	1	3	1
10M40	4	1	4	1
12M40	5	1	5	1
14M50	6	1	6	1
16M50	7	1	7	1
18M50	8	1	8	1
20M50	9	1	9	1
22M50	10	1	10	1

## 2.3 DETERMINING WHICH SECTION LENGTH SHOULD BE USED

The example given is of a FD190 12M40, standard (i.e. not delivered to a shipyard), for a forestay measuring between 10.4 and 12.4 metres. According to the table above, you will receive: 5 two-metre external sections and 1 one-metre external section.

**EXAMPLE No1** : your forestay measures between **10.40 and 11.40 metres (fig. A)**, you do not need the 1-metre section.

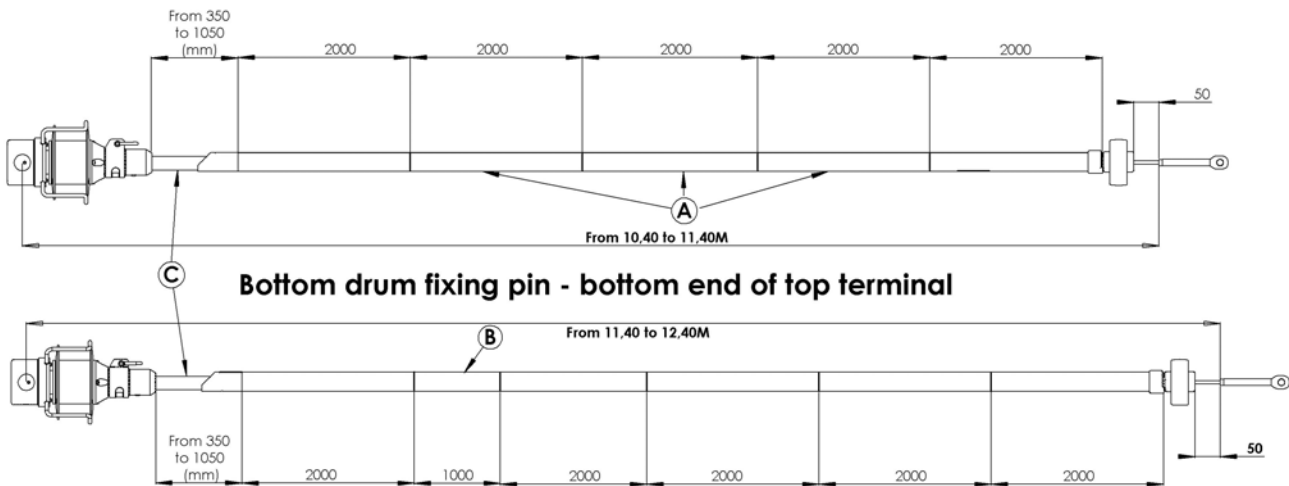

**EXAMPLE No2:** your forestay measures between **11.40 and 12.40 metres**, you do need the 1-metre section (**fig. B**); the latter fits above the last section.

**In both examples, the exact length will be reached with the telescopic section (fig. C).**

### 3- PRE-INSTALLATION NOTES

#### 3.1 GENERAL REMARKS WITH REGARD TO FACNOR FURLING SYSTEM:

■ **Simple to assemble: no mast unstepping, no section cutting, no drilling**

The FACNOR headsail furling system is one of the easiest to install:

- it does **not require unstepping the mast**
- under most circumstances you **will not need to cut any section on account of the patented Facnor telescopic section.**
- **no drilling** is necessary.

■ **Maintenance**

The FlatDeck **does not require any specific maintenance** as the drum and the swivel are fitted with torlon® bearings. Just clean the mechanisms several times each season to remove the salt deposits. Hose the mechanisms as shown. There is a hole in the upper part of the drum specially designed for flushing.



#### 3.2 ELECTRICAL DANGER AND MAST SUPPORT



**DO NOT BRING YOUR FURLING SYSTEM IN CONTACT WITH ELECTRIC CABLES OR HIGH TENSION LINES.** The headsail reefing system is made from aluminium sections which are highly conductive. Contact by the system with power lines can be fatal.



**DO NOT INSTALL YOUR REEFING SYSTEM WHEN STORMY WEATHER HAS BEEN FORECAST.** A lightning striking the mast can travel down the system. Death could result from shocks induced from touching the reefing system.



**MAKE SURE THE MAST IS SECURED BEFORE REMOVING THE BOTTOM FIXING PIN OF THE FORESTAY.** Facnor reefing system can be assembled with the forestay in place. Kit components will be fed over the bottom of the forestay. Therefore, the bottom fixing pin will have to be removed. Before operating, support the front mast with a Spinnaker or Genoa halyard. **DO NOT USE A SNAP SHACKLE OR SHACKLE HALYARD BUT LASH IT.**



*We recommend that you change your forestay if it is too old. You may contact one of our dealers. For information about the nearest Facnor retailer, contact us at +33 (0)2 33 88 50 22 or visit our web site : [www.facnor.com](http://www.facnor.com) .*

**The services of a professional yacht rigger or sailmaker could end up saving you time and should you improperly install the furler or encounter an unusual rigging problem.**

### 3.3- PREPARING FOR ASSEMBLY:

#### ■ Protecting the components

During assembly, we recommend you protect both the sections and the other items of the furling system, as rough ground may damage them.

#### ■ Tools needed for assembly :

- a manual or electric screwdriver
- a hammer
- an adjustable spanner for the lower drum connection bolt

Different allen keys are supplied with the kit, as well as the Pozi drive/No2 bit for the section screws.

#### ■ Preparing foil sections

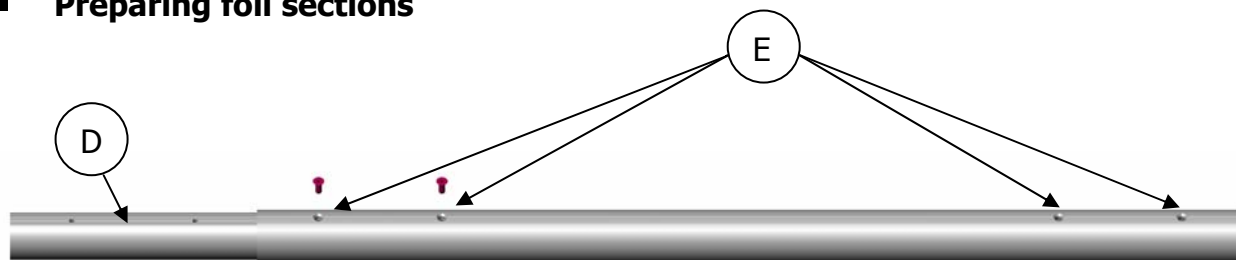

We recommend you prepare the sections before assembly. This involves fixing a connector (fig. D) to all of the twin-groove sections apart from one. The latter will be the top section. All of the external sections, **including the top section\***, have symmetrical holes at each end (fig. E).

**BEWARE: DO NOT TIGHTEN SCREWS AT THIS STAGE.**

 \* For furling systems installed for the first time, delivered to the shipyard, the top section may be shorter than 2 metres. For these reefing systems, the top section is cut to length. Therefore, there is no hole on the upper end of the top section, on which the top cap will be fixed.



## 4- ASSEMBLY STAGES :

### 4.1 – ASSEMBLY OF THE HALYARD DEFLECTOR\*

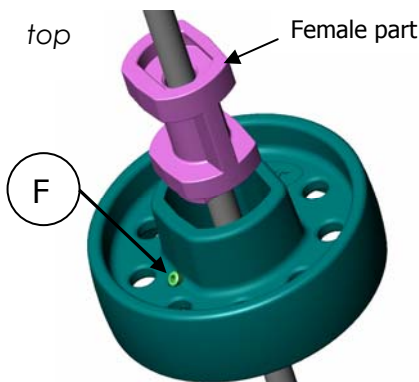

Slip the disk around the forestay, screw pointing up. Assemble the two half bushings **above** the deflector disk and around the forestay, the "female" part pointing up. Fit the bushing into the halyard deflector. Then tighten the screw (fig. F), which will fix the bushing in place.

### 4.2- ASSEMBLY OF THE TOP CAP AND THE TOP SECTION

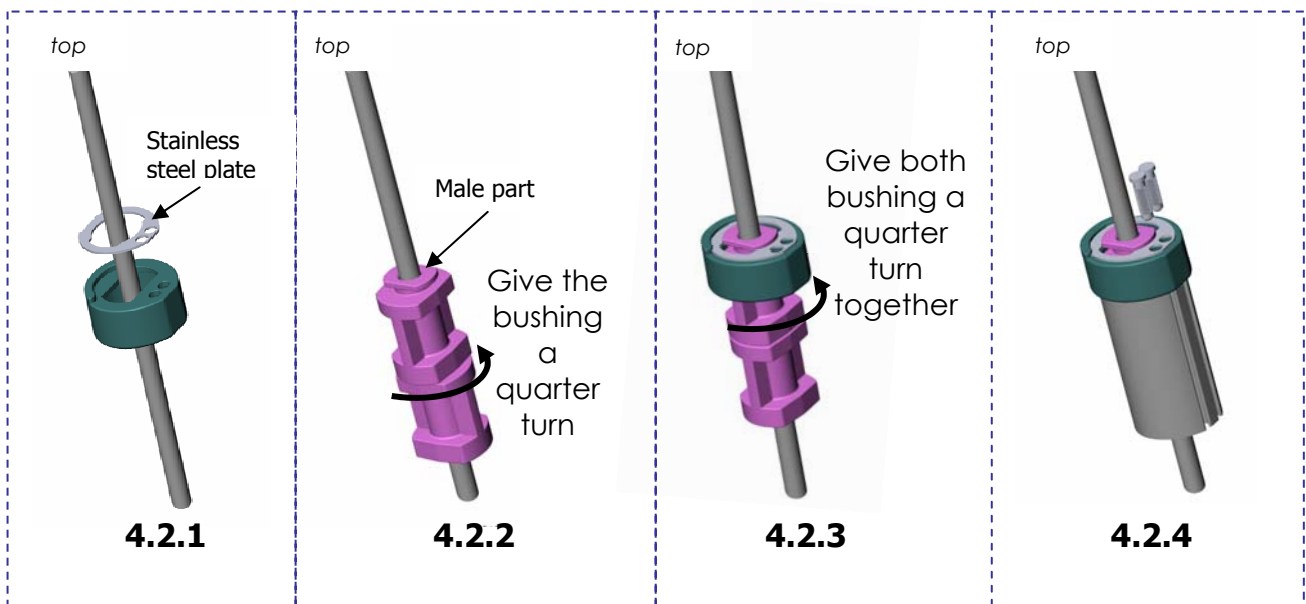

4.2.1- Slip the stainless steel plate and then the top cap around the forestay. Position the plate by slipping it into the notches on the cap, designed for this purpose.

4.2.2- Around the forestay, assemble a 1<sup>st</sup> bushing, then a 2<sup>nd</sup>, the "male" part pointing up. Fit the bushings together, and give the bottom bushing a quarter turn.

**⚠ IMPORTANT : These two bushings are now joined.**

4.2.3- Put the bushing set into the cap, then give another quarter turn to the bushings.

**⚠ IMPORTANT : Doing this ensures that the bushings are fixed in place in the top cap.**

4.2.4- Take the top section and fix it snugly into the top cap. If assembly is not possible, give the bushings a half turn in the cap.

Place the 2 pins into the holes in the top cap and the stainless steel plate. Then, tap them into the section grooves with a mallet.



*The pins are simply used to fix the cap. Therefore, do not hit too hard or you may damage the cap.*



### 4.3- FITTING THE HALYARD SWIVEL

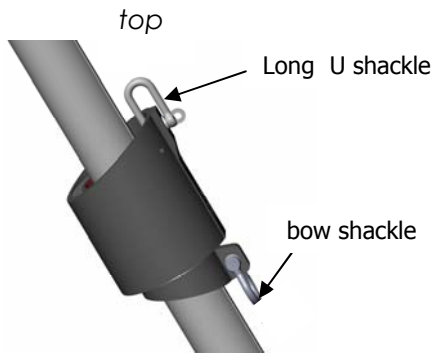

Ensure you fit the halyard swivel the right way up. Fix the two shackles. In order to raise the sections as high as possible, we recommend that you fit the halyard swivel and raise everything by way of a halyard.

**⚠ IMPORTANT :** Be sure to attach a down haul line to the halyard swivel so as to be able to recover it later.

### 4.4- ASSEMBLING FOIL SECTIONS

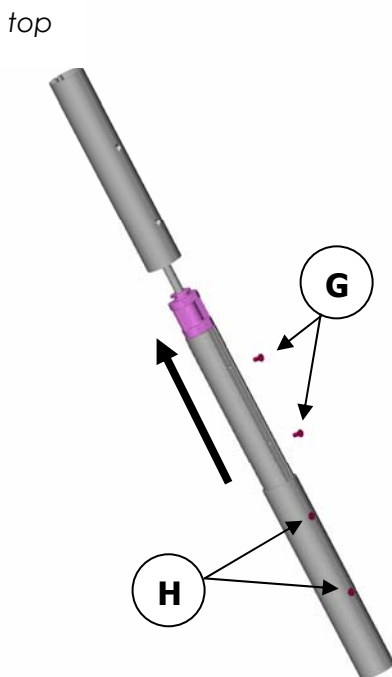

The top section is in place. Assemble a bushing around the forestay. Slip the next section, already assembled (see preparing the sections p.4), with the connector pointing towards the top of the forestay. With the help of the connector, push the bushing all the way up into the top section until the connector holes coincide with those of the top section.

Fit both screws (fig. G). then, slowly and firmly tighten the 4 screws (fig. G+H).

Repeat the operation until you reach the last section. DO NOT FIX ANYTHING TO THE LAST SECTION.



*If your forestay requires the use of a 1-meter section, fit it above the lowest 2-meter section.*

### 4.5- FITTING THE TELESCOPIC SECTION

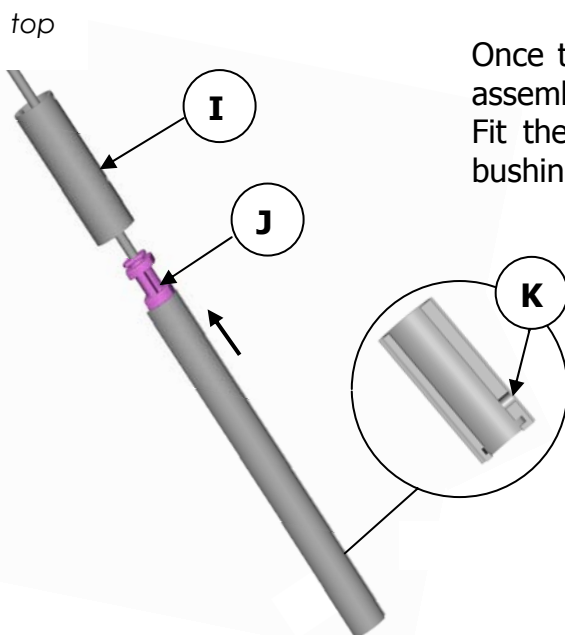

Once the sections have been hoisted as high as possible, assemble a bushing around the forestay.

Fit the telescopic section and push it up. That way, the bushing (fig. J) goes into the lowest foil section (Rep. I).



**BEWARE :** FIT THE TELESCOPIC SECTION TO THE FORESTAY AS INDICATED (fig. K). THE SIDE WITH ONLY ONE HOLE MUST BE POINTING DOWN.

#### 4.6- FITTING THE FEEDER

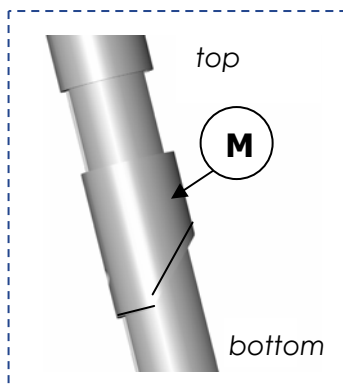

First fit the sail feeder (fig. M) to the telescopic section as indicated.

#### 4.7- FITTING THE BUSHING INTO THE TELESCOPIC SECTION

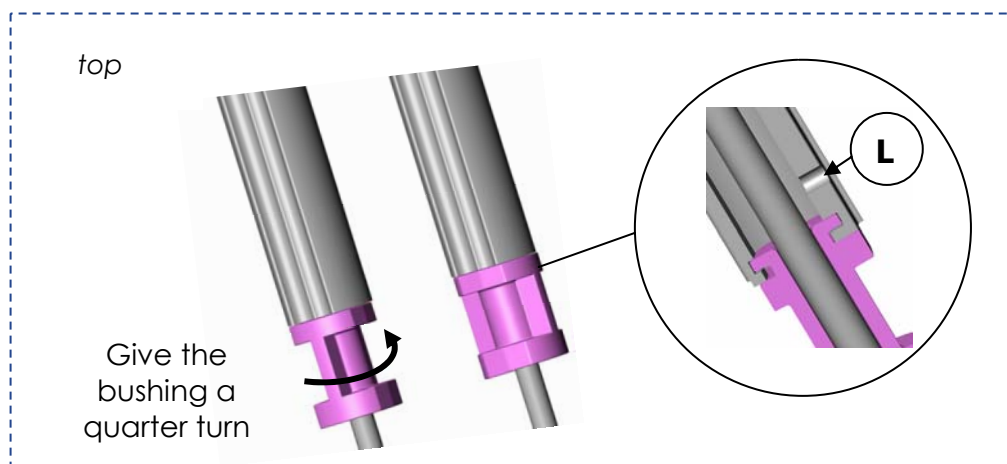

Assemble one bushing beneath the telescopic section, the male side pointing up. Fit the bushing to the telescopic section and give it a quarter turn.

**⚠ IMPORTANT: Doing this ensures that the bushing is fixed in place at the bottom of the telescopic section (fig. L).**

#### 4.8- FIXING THE TELESCOPIC SECTION IN THE DRUM

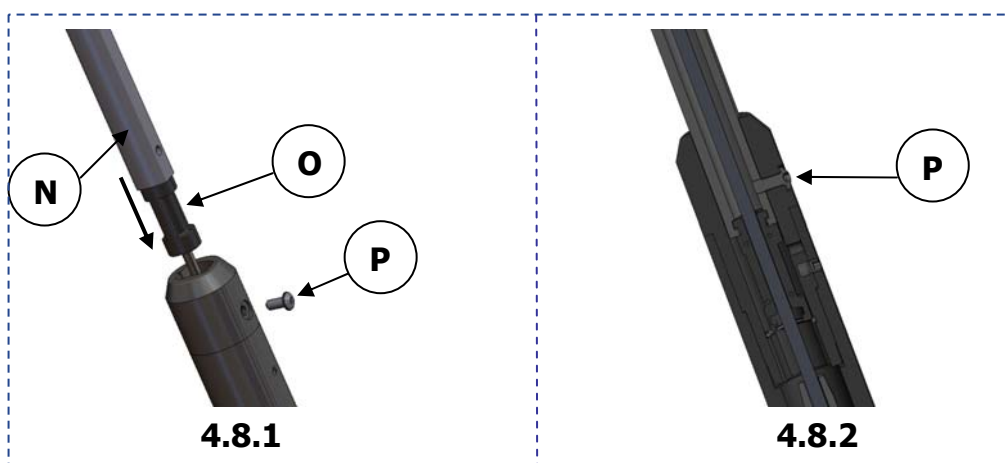

4.8.1- Slip the drum around the forestay. Loosen the screw (fig. P) slightly but sufficiently so that the telescopic section can slide inside the nose of the drum. Lower the telescopic section (fig. N), with its bushing (fig. O), until the bushing fits in snugly.

4.8.2- Tighten the locking screw (fig. P), which will join the drum to the telescopic section.

#### 4.9- FIXING THE BOTTOM OF THE DRUM

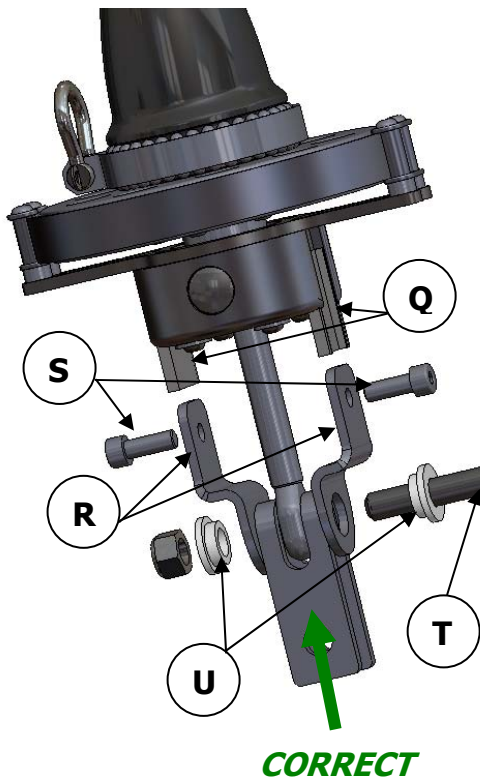

Slip the two flexible plastic strips (fig. Q) into the slots situated on either side of the drum's base.

Fix the top of the stainless steel link plates (fig. R), found in the «Facnor turnbuckle kit», to the drum with the screws provided (fig. S). Lightly grease both threads before fixing.

Then, fix the bottom of the plates to the turnbuckle with the pin (fig. T), being careful to correctly position the nylon bushes (fig. U).

**⚠ BEWARE: THE FITTING PIN (FIG. T) MUST ALWAYS BE FIXED TO THE UPPER SECTION OF THE JAW.**

**⚠ NEVER FIX THE BOTTOM OF THE PLATES IN THE LOWER SECTION OF THE JAW.**

WITH SUCH AN INSTALLATION THE FORESTAY IS NOT CORRECTLY ARTICULATED.

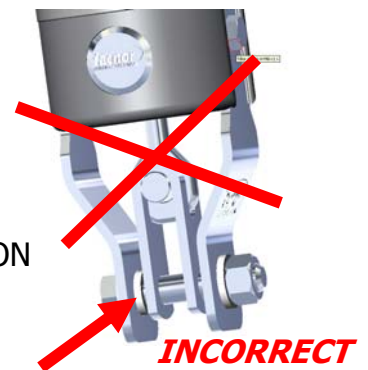

**IMPORTANT :** In order to reach the optimum articulation of the forestay fitted with a furling system, it is absolutely necessary to have a toggle at the top end of the forestay. Furthermore, concerning the bottom terminal, it is recommended to have also a toggle.

#### 4.10- ADJUSTING SECTIONS

Tighten the backstay to put some tension onto the forestay.

Leave the feeder piece resting on the drum.

Raise all of the sections together until they touch the top terminal of the forestay. Insert a screw into one of the lower holes of the last section.

**⚠ BEWARE: DO NOT OVERTIGHTEN IT.** Press the screw with your thumb and let the sections slowly descend until a hole coincides with the first of the threads on the telescopic section.

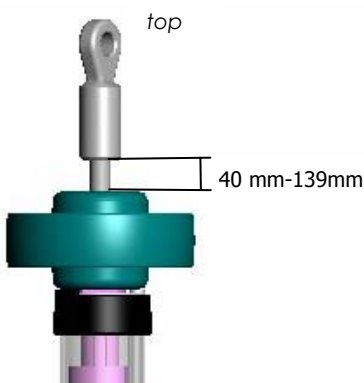

**⚠ IMPORTANT :**

- Make sure that sections have descended at least 50mm before the screw slots into place. Otherwise, proceed to the next hole, 100mm below.
- Leave a margin of 40-139 mm between the halyard deflector and the bottom of the forestay top terminal.
- The ideal position of the feeder is between 600 and 800 mm above the drum shackle.

#### 4.11- FITTING THE SAIL FEEDER

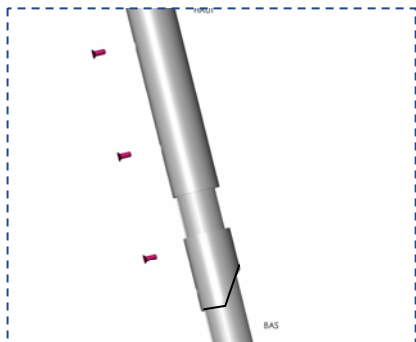

At this step, the bottom foil section being assembled, the feeder needs finally to be screwed.

Align the holes in the telescopic section with holes in the feeder. Then, screw down the feeder with the screw provided.

### 5- INSTALLATION OF THE REEFING LINE/WEBBING

#### 5.1 Mise en place de la drosse

The furling line/webbing of the FlatDeck is fitted as any traditional furling line. Use the special blocks delivered. Furl in and out as a test in order to check the correct position of the swivel: just in front of the cleat (sail furled in) and just behind the drum (sail furled out). If the swivel is correctly positioned, then it is not necessary to cut the webbing. However:

- ⇒ If the swivel is situated behind the cleat, the webbing needs to be shortened (see 5.3).
- ⇒ If the swivel is not close to the drum, then turn the Genoa sheets round the forestay.

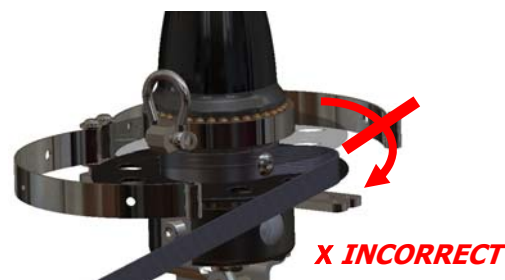
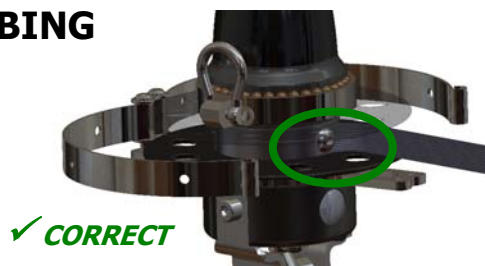

#### 5.2 Fitting the front deck block



The furling line should be installed as shown on the drawing.

The furling line should run off at 90° to the forestay (if the webbing guide is uncorrectly positioned, see 6. hereafter)  
Fit the front deck as far as possible from the drum.

#### 5.3 Cutting the webbing (if the swivel is situated behind the cleat)

The length of the delivered webbing corresponds to the maximum length that can be rolled round the drum. According to the boat configuration, the webbing may need to be cut. It is better to keep the maximum webbing within the drum for an optimum furling power.

1. Count the number **X** of turns of foil sections necessary to tightly and completely furl the sail (keep the sheets under tension)



2. Measure the distance **D** from the drum to the rope cleat.

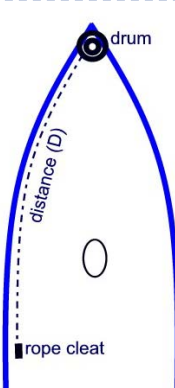

3. See the chart hereafter and match the **X** and **D** datas with the length **L** of the webbing



Lgth L webbing (m) <b>FD110</b>	Distance D from the drum to cleat in m (webbing running on the deck)										
	3,5	4	4,5	5	5,5	6	6,5	7	7,5	8	
« X+1 » or « X+2 »* turns to roll in the sail	12	-	4,6	6,3	7,2	7,2	7,2	7,2	7,2	7,2	7,2
	13	-	-	5,4	6,7	7,2	7,2	7,2	7,2	7,2	7,2
	14	-	-	4,6	5,84	7,2	7,2	7,2	7,2	7,2	7,2
	15	-	-	-	5,42	6,7	7,2	7,2	7,2	7,2	7,2
	16	-	-	-	-	5,8	7,2	7,2	7,2	7,2	7,2
	17	-	-	-	-	-	6,7	7,2	7,2	7,2	7,2
	18	-	-	-	-	-	-	7,2	7,2	7,2	7,2
	19	-	-	-	-	-	-	6,7	7,2	7,2	7,2
	20	-	-	-	-	-	-	-	7,2	7,2	7,2

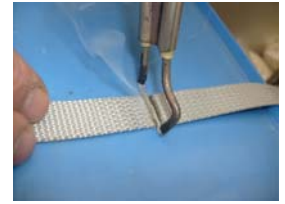

Cut the webbing with a heat cutter.

Lgth L webbing <b>FD19/230-</b>	Distance D from the drum to cleat in m (webbing running on the deck)														
	4	4,5	5	5,5	6	6,5	7	7,5	8	8,5	9	9,5	10	10,5	11
« X+1 » ou « X+2 »* turns to roll in the sail	12	-	4,7	6,5	8,5	10,6	13,0	13,0	13,0	13,0	13,0	13,0	13,0	13,0	13,0
	13	-	-	5,6	7	9,0	10,6	13,0	13,0	13,0	13,0	13,0	13,0	13,0	13,0
	14	-	-	-	6	7,5	9,5	11,2	13,0	13,0	13,0	13,0	13,0	13,0	13,0
	15	-	-	-	-	6,5	8,0	9,5	11,2	13,0	13,0	13,0	13,0	13,0	13,0
	16	-	-	-	-	-	7,0	8,5	10,1	11,8	13,0	13,0	13,0	13,0	13,0
	17	-	-	-	-	-	-	7,5	9,0	10,6	11,8	13,0	13,0	13,0	13,0
	18	-	-	-	-	-	-	-	8,0	9,5	10,6	13,0	13,0	13,0	13,0
	19	-	-	-	-	-	-	-	-	8,5	9,5	11,2	13,0	13,0	13,0
	20	-	-	-	-	-	-	-	-	-	9,0	10,1	11,2	13,0	13,0
	21	-	-	-	-	-	-	-	-	-	-	9,5	10,6	11,8	13,0
	22	-	-	-	-	-	-	-	-	-	-	-	10,1	11,2	13,0

Lgth L webbing (m) <b>FD310</b>	Distance D entre enrouleur et taquet en m (cheminement sangle sur pont))														
	5	5,5	6	6,5	7	7,5	8	8,5	9	9,5	10	10,5	11	11,5	
« X+1 » ou « X+2 »* turns to roll in the sail	12	-	6,5	8,7	11,0	13,5	15,5	18,3	21,3	21,3	21,3	21,3	21,3	21,3	21,3
	13	-	-	7,0	9,2	11,0	13,5	15,5	18,3	20,5	21,3	21,3	21,3	21,3	21,3
	14	-	-	-	7,6	9,2	11,0	13,5	15,5	17,6	19,8	21,3	21,3	21,3	21,3
	15	-	-	-	-	8,1	9,8	11,6	13,5	15,5	17,6	19,8	21,3	21,3	21,3
	16	-	-	-	-	-	8,1	9,8	11,6	13,5	15,5	16,9	19,0	21,3	21,3
	17	-	-	-	-	-	-	8,7	10,4	11,6	13,5	15,5	16,9	19,2	21,3
	18	-	-	-	-	-	-	-	9,2	10,4	12,2	13,5	15,5	16,9	19,0
	19	-	-	-	-	-	-	-	-	9,2	11,0	12,2	13,5	15,5	16,9
	20	-	-	-	-	-	-	-	-	-	9,8	11,0	12,2	14,1	15,5
	21	-	-	-	-	-	-	-	-	-	-	-	11,6	12,8	14,1
	22	-	-	-	-	-	-	-	-	-	-	-	-	11,6	12,8

Lgth L webbing (m) <b>FD310</b>	Distance D entre enrouleur et taquet en m (cheminement sangle sur pont))							
	12	12,5	13	13,5	14	14,5		
« X+1 » ou « X+2 »* turns to roll in the sail	12	-	21,3	21,3	21,3	21,3	21,3	21,3
	13	-	21,3	21,3	21,3	21,3	21,3	21,3
	14	-	21,3	21,3	21,3	21,3	21,3	21,3
	15	-	21,3	21,3	21,3	21,3	21,3	21,3
	16	-	21,3	21,3	21,3	21,3	21,3	21,3
	17	-	21,3	21,3	21,3	21,3	21,3	21,3
	18	-	20,5	21,3	21,3	21,3	21,3	21,3
	19	-	19,0	20,5	21,3	21,3	21,3	21,3
	20	-	16,9	18,3	20,5	21,3	21,3	21,3
	21	-	15,5	16,9	18,3	20,5	21,3	21,3
	22	-	14,1	15,5	16,9	18,3	19,8	21,3

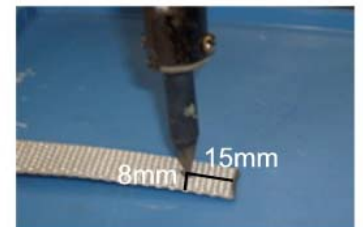

Make a hole at mid-width and at 1.5cm from the edge with the sharp point of a soldering.

\*add one turn in order to secure the furling or 2 turns if the sail is new

If the length of the webbing (L) match to an empty box in one of these charts above, then the furling line must run longer (distance D) by adding a block at the back of the boat.

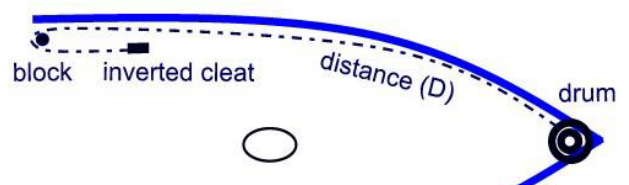



## 5.4 Fitting the webbing into the drum

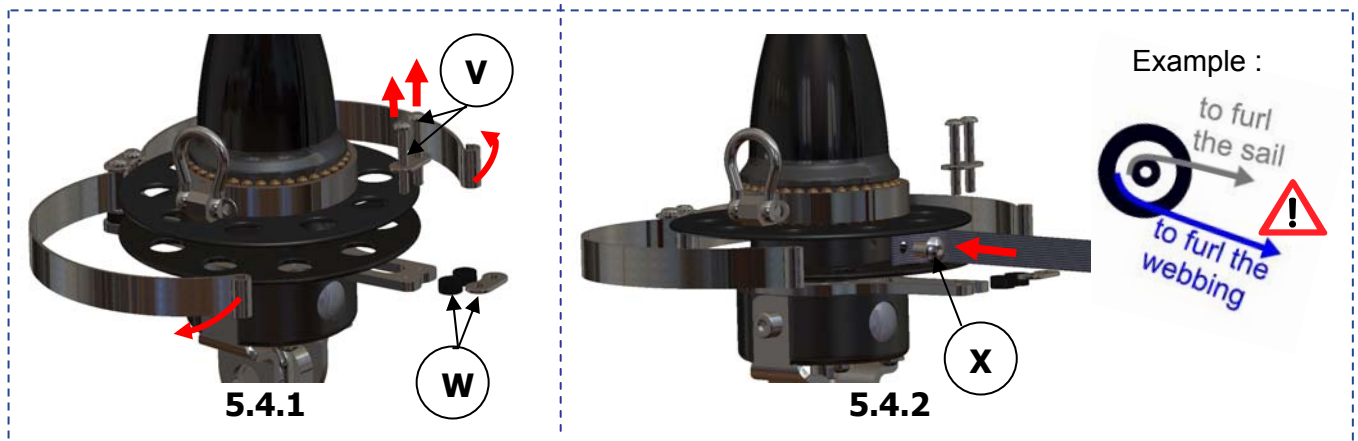

5.4.1 & 5.4.2- Remove the stainless steel screws (Rep. V). Be careful not to lose the washers (Rep. W) and notice the way these parts are installed. Then, open the guide to access the webbing fixing screws (Rep. X). Remove the hex socket screw (Rep. X) and introduce the screw through the hole at the end of the webbing. Fix the webbing to the drum by tightening the hex socket screw (Rep. X). When fitting the webbing load the drum according to the UV strip fitted to the sail. UV strip must be covering the sail when the sail is furled.

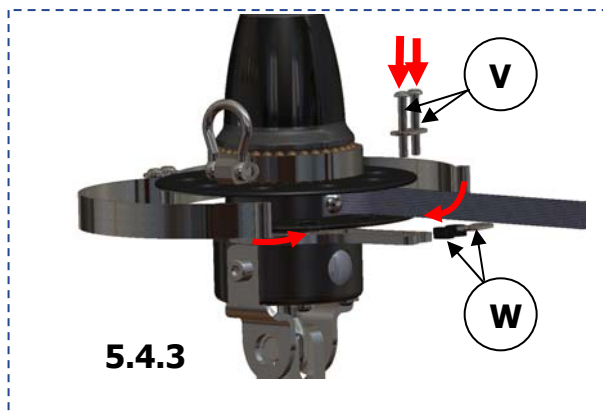

5.4.3- Close up the stainless steel webbing guide and fix the screws (Rep. V) with the washers (Rep. W) as shown.

## 6- ADJUSTING THE FURLING LINE GUIDE

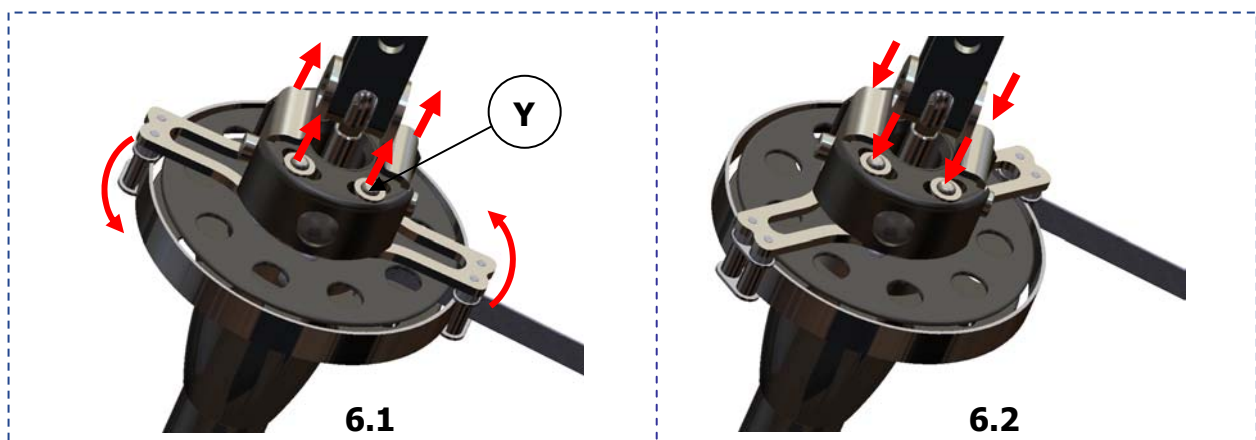

6.1- Loosen the 4 stainless steel fixing screws (Rep. Y) in order to release the rotation of the guide. Turn the guide to the appropriate position.

6.2- Tighten the 4 stainless steel fixing screws (Rep. Y) firmly but not too much.

 If the rotation angle is not sufficient, fix the 4 screws (Rep. Y) into the 4 next adjusting holes.

## 8- SPECIFIC INSTALLATIONS

Installation without deflector wheel or when using a sail with shorter luff:

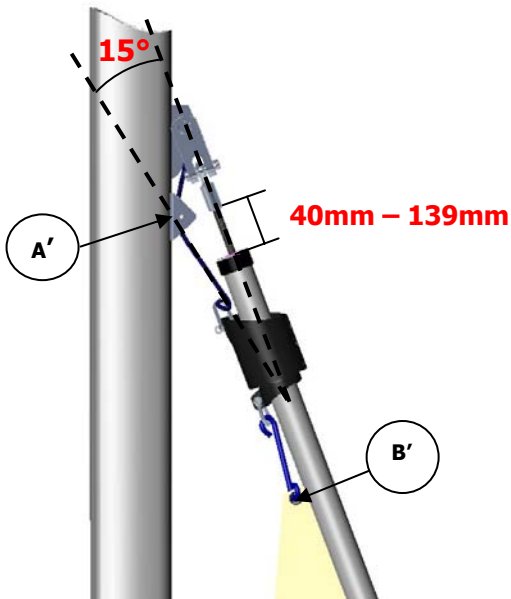

- Without deflector wheel (installation for the LS/LX330):

If the halyard swivel is not used, fix a block on the mast (fig. A'), so that the halyard runs off at 15° to the forestay. Also insure that the top cap is positioned between 40mm and 139mm from the bottom end of the forestay terminal.

- Sail with shorter luff (i.e. Storm Sails and Working Jibs):  
The halyard swivel virtually eliminates halyard wrap ; however, when using a shorter sail, rig a short strop (fig. B') between the head of your sail to allow the top of the halyard swivel to be positioned around 50mm from the top section cap, when your sail is fully hoisted.

## 8- POST-INSTALLATION CHECK LIST

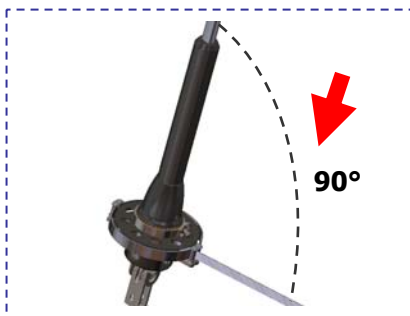

- The furling line runs at 90° to the foil sections**  
(if not, see p.30 «adjusting the furling line guide)

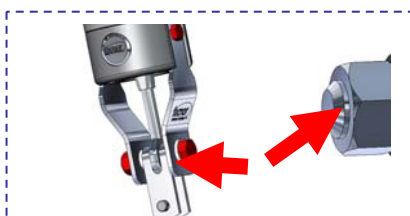

- The bottom pin of the forestay is correctly bolted, at least one thread is showed beyond the bolt**  
(if the furling system is fitted with link plates, check the upper fixing screws)

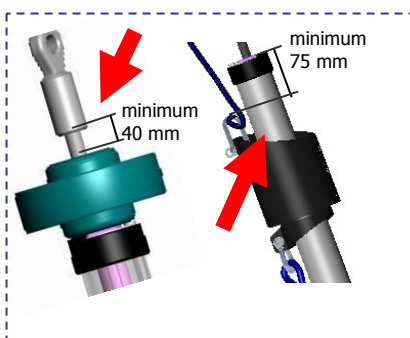

- When the sail is hoisted and the halyard is tensioned correctly :
- distance between halyard deflector & bottom end of the top forestay terminal = 40mm minimum – 139mm maximum**

- distance between halyard swivel & top cap = 75mm minimum – 150 mm maximum\***



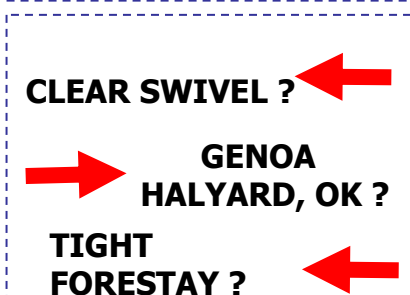



*Recommended datas (may vary according to rigging fitting)  
\* space to allow for change in luff length of Genoa. The bigger is the distance between the top swivel and the top cap, the more important is the risk for the halyard to twist round the forestay. Make sure that the halyard/forestay angle is bigger than 15° (if not, see page 29)*



- The swivel is clear of any halyard**
- The Genoa halyard is correctly tensioned**
- The forestay is sufficiently tight**



## 11- FURLING TIPS

-  When you reef, check the Genoa car to ensure the correct tension on the leach and foot.
  -  Keep the Genoa halyard tight when furling in and out.
  -  It is recommended that you have a spare sail on board. You can use an old Genoa with a luff tape to fit the Facnor groove.
  -  Before leaving your boat, make sure that the sail is tightly furled and that the jib sheets are wrapped around the furled sail two or three times, and the reefing line is secured.
  -  When reefing in light airs, maintain some tension on the jib sheets to ensure the sail is properly rolled up.
-  **DO NOT FORCE** the reefing system. Check for reasons if the sail is difficult to furl.



*Please do not hesitate to contact our experienced sales team or the FACNOR dealers whose list is available on our web site : [www.facnor.com](http://www.facnor.com) and discover the wide range of FACNOR products.*

***ENJOY YOUR SAILING !***

***[www.facnor.com](http://www.facnor.com)***